

General Electric Company
GE Energy

Hawaii Public-Private Partnerships



Hawaiian Electric
Company



Hawaii Natural
Energy Institute



State of
Hawaii



General Electric
Company



Sentech



USDOE

Bruce Norman

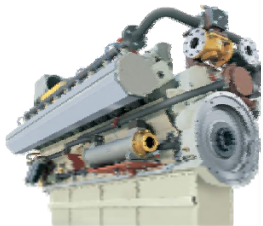

Overview



- **Global Trends**
- **Private Industry Initiatives**
- **Public – Private Partnerships in Hawaii**

Diverse Global Power Generation Solutions



Fuels

Conversion

Delivery

- 
- Gas
 - Oil
 - Coal
 - Nuclear
 - Geothermal
 - Biomass
 - Hydro
 - Wind
 - Solar

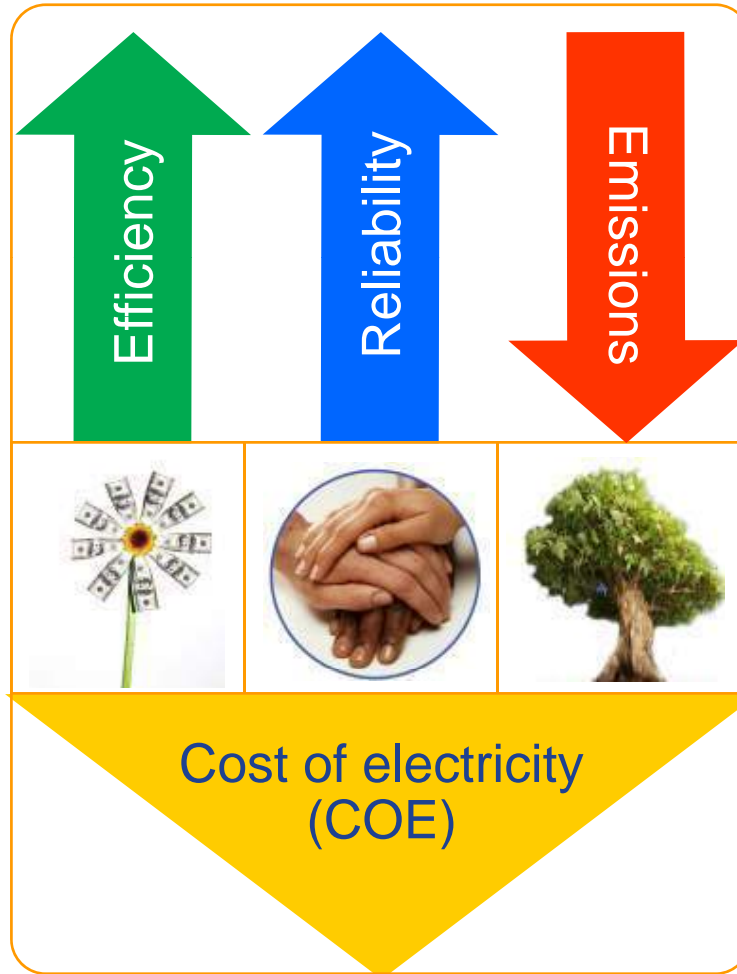

Growing renewables demand ...



Global renewable installed capacity (GWs)

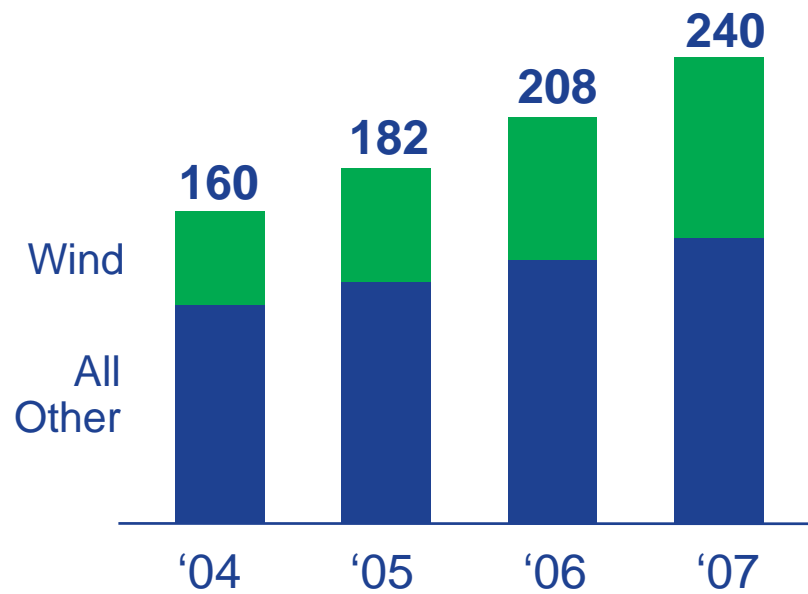

Source: REN21 2007 Preliminary + GWEC

- ✓ Significant growth ... 25% CAGR ('04-'07)
- ✓ 40% power capital spending
- ✓ Wind >50% of growth
- ✓ Domestic, abundant, carbon-free
- ✓ Countries & US states establishing renewable energy targets



World requiring renewable energy solutions

Growing demand for solar energy...

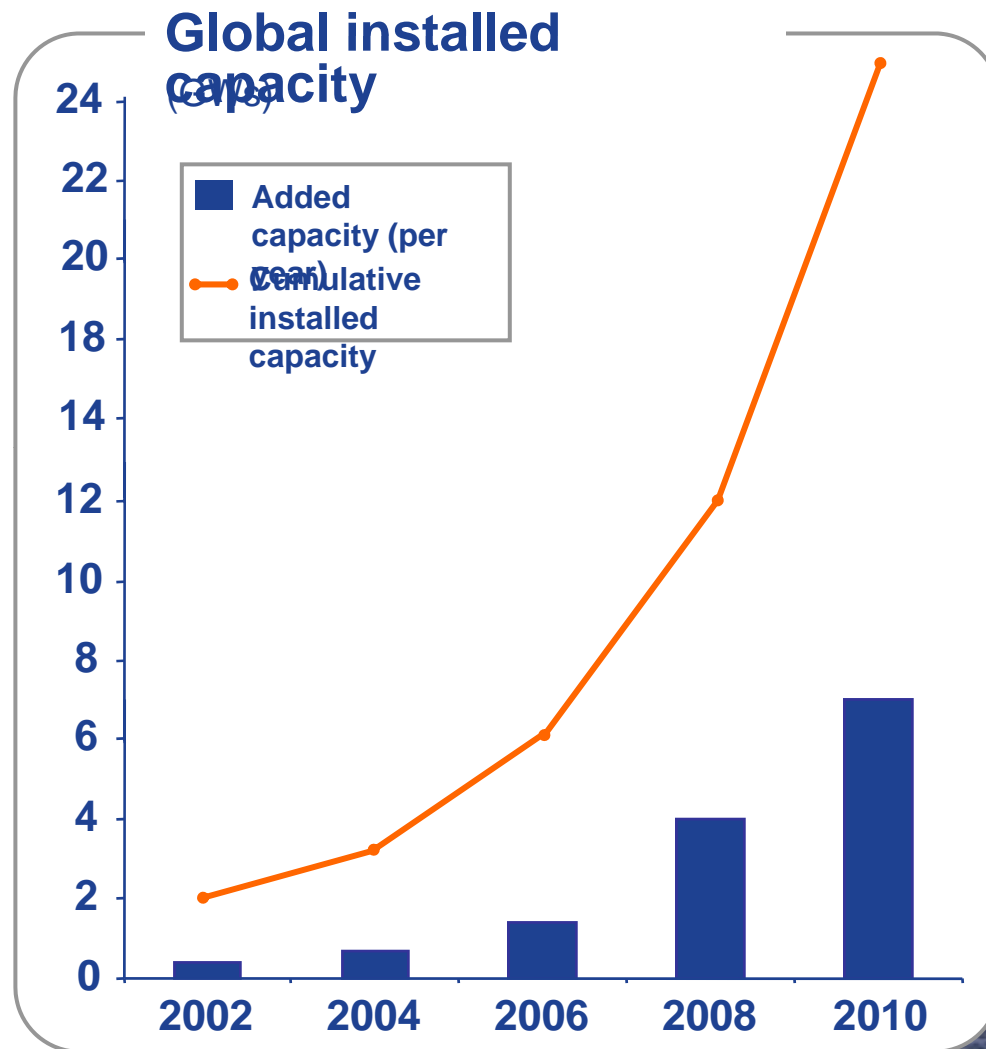

- ### Highlights
- Significant growth ... 40% Cumulative Annual Growth Rate ('02-'10)
 - Solar \$17B+ segment ('07)
 - 50% increase in cumulative installed capacity in both '06 & '07
 - Countries & US states establishing renewable energy targets
 - Abundant, natural and carbon free

Source: European Photovoltaic Industry Association
– Global Market Outlook for Photovoltaics through 2012

Ocean Energy Sources – Emerging Technologies



Current

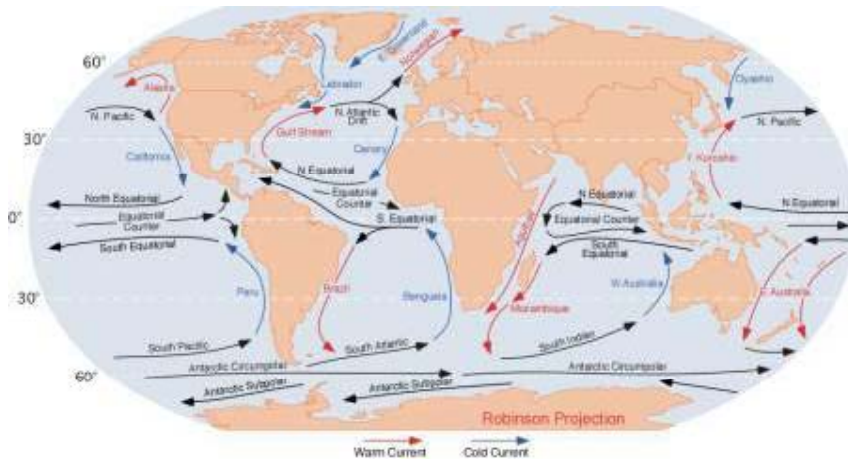

Wave

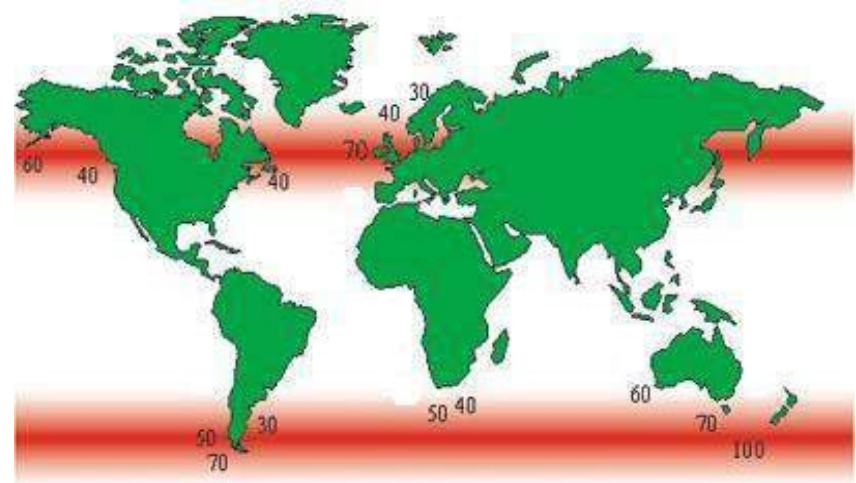

Tidal

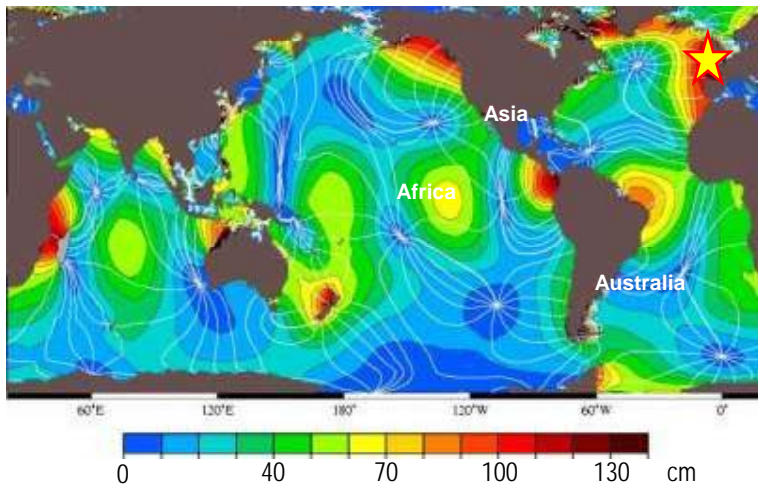

Vast Resources – What is Accessible?

GE's growing renewables global footprint



Wind

- Leading N. American wind turbine supplier
- 6x unit growth since '02
- 8,500+ 1.5MW installed globally



Solar

- Residential, commercial and utility applications
- PrimeStar Solar thin film technology investment

Biogas

- Power range: 0.25 MW-4 MW
- Fuel flexibility: Natural gas or a variety of renewable or alternative gases



GE is committed long term... **ecomagination**



GE's commitment to imagine and build innovative solutions that benefit our customers and society at large.

Our commitments include:

- Doubling our research investment
- Introducing more ecomagination products
- Reducing greenhouse gas emissions
- Make customers true partners
- Keeping the public informed



A Strong Partnership in Hawaii

**GE / Sentech / Hawaii Natural Energy Institute /
HECO utilities / Department of Energy / DBEDT**



Developing tools to identify economically viable technologies to transform the energy infrastructure

- **Develop and validate models for electricity and transportation**
- **Align with DOE mission, State of Hawaii objectives, and utility system needs**
- **Develop technology-neutral process that can be used elsewhere**

Identify and analyze scenarios for deployment of new energy systems

- **Identify key stakeholder-based performance metrics**
- **Develop site-specific conceptual designs**
 - e.g.: energy storage + renewable energy systems
- **Address:**
 - **systems integration (grid stability)**
 - **institutional considerations (impacts of PPA contracts, etc.)**
 - **site specific issues (environmental, cultural, societal)**

Public-Private Partnerships in Hawaii

Present Programs

Maui Grid Study

Develop power systems models to understand the economic/performance impacts of wind power & the mitigation technologies needed to increase penetration

Big Island Energy Roadmap

Evaluate scenarios to identify the performance of various technology approaches to increase the penetration of renewable energy.

Maui Grid Modernization

Deploy energy storage, generation and demand-side management technologies to reduce peak load and enable further expansion of renewable energy on Maui.

Future Opportunities

Oahu Grid Study

Develop power systems model, with HECO, to understand the economic & performance impacts of renewable power.

Military Community Demonstration Project

Develop algorithms and controls platform to enable demand response and control of distributed energy resources for a military community in Hawaii.

Kauai Grid Study

Partnering with KIUC to develop a power system models to understand the impact of increased penetration of renewable energy on the grid.

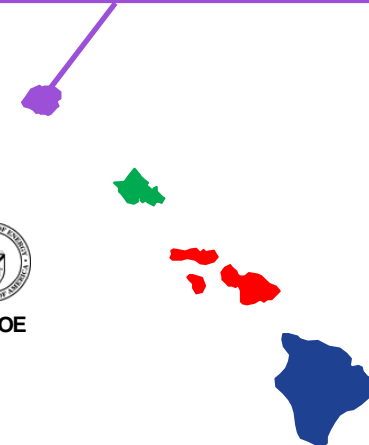

Maui Grid Study

Addressing the Challenges of Higher Penetrations of Wind Power

Development of engineering tools to assess the impact of wind power expansions on the island of Maui. These tools can be leveraged to quantify the benefits of different technologies that address the variability of wind ρ

Phase 1 - Develop, calibrate and validate models of the Maui Grid

- Completed in September, 2008.

Phase 2 - Utilize these models to assess the economic and performance impacts of additional wind penetration and develop mitigating solutions for addressing the challenges.

- Discussion underway

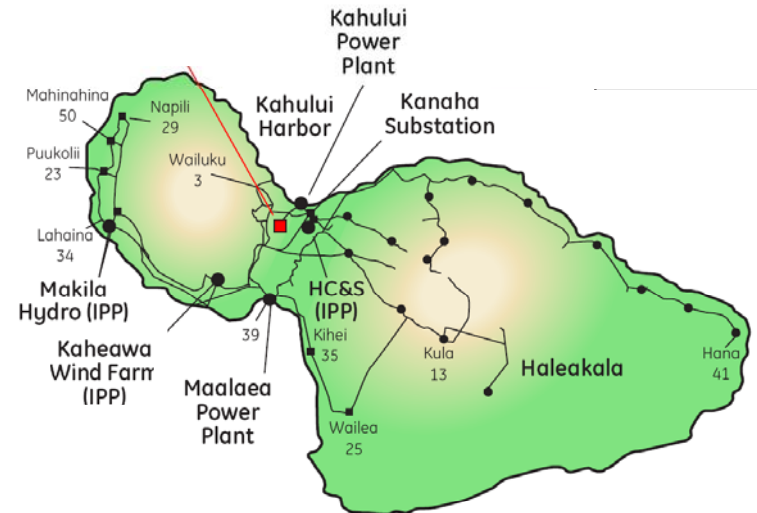

Maui Grid Modernization

\$15MM DOE / HECO / GE Smart Grid Development & Demo



Develop a controls and communication architecture capable of *coordinating DG, energy storage and controllable loads to:*

- Reduce peak load by 15% on a substation in Maui.
- Mitigate the impacts of wind variability on the Maui grid.

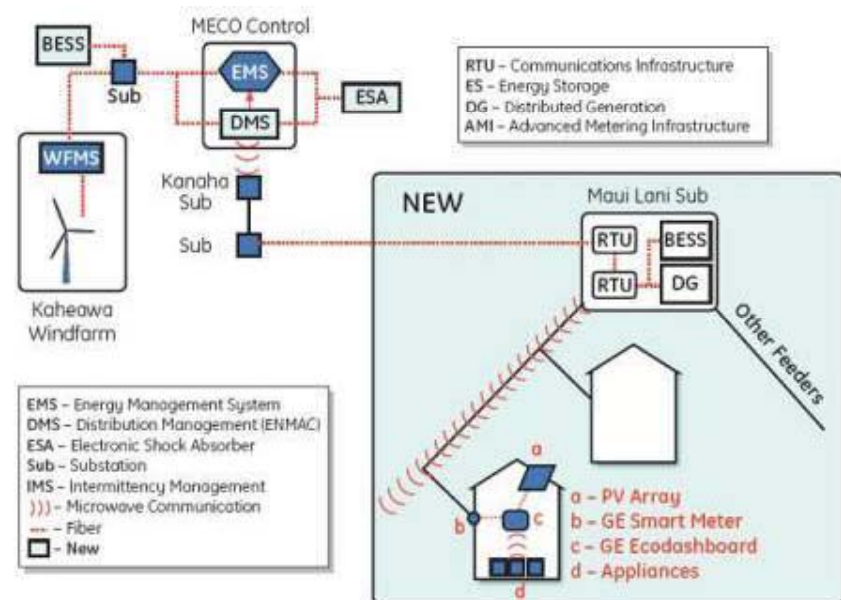
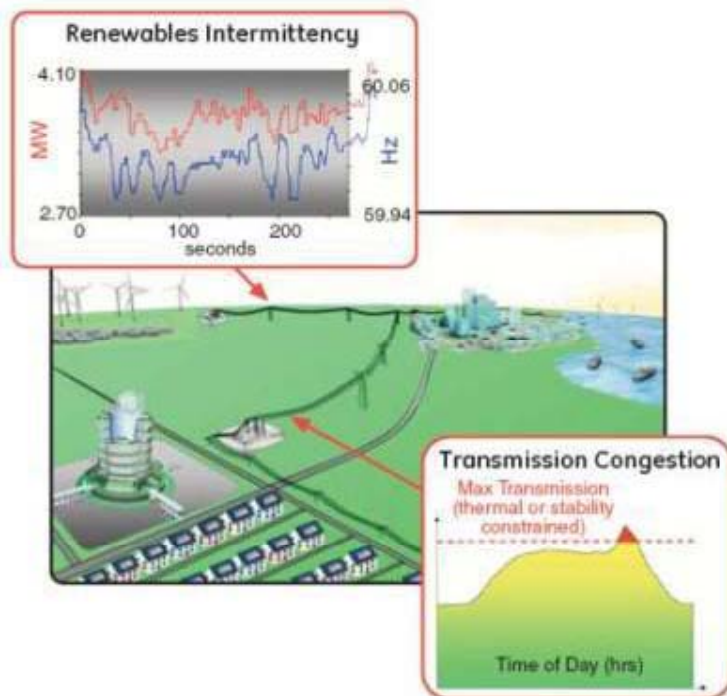

Next Steps...

- **Continue to work with the Hawaii utilities, the DOE and the State to achieve their missions... Making informed decisions in the presence of rapid change.**
- **Continue to develop technologies, through the public/private partnership, that enable higher penetrations of renewable energy**
- **Showcase technology demonstrations with Hawaii utilities and other partners that help achieve the State's renewable energy objectives.**